



# Randolph Mountain Club Newsletter

The mission of the Randolph Mountain Club is to promote the enjoyment of the Randolph area through hiking, trail development and maintenance, upkeep of camps and shelters, and the sharing of the collective knowledge of its members.

December 2022

Volume 20, No. 2

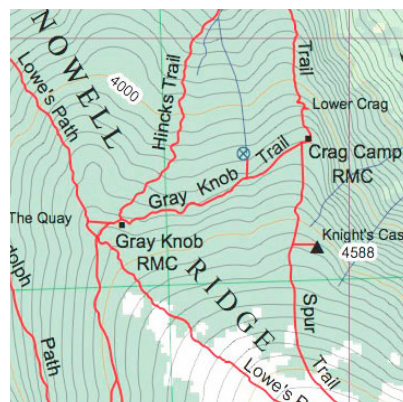

## Hiker Rescue on Lowe's Path

From caretaker Andi Smith's chronicle of a rescue she and Renée Koma performed on June 16, 2022, during extreme weather that endangered hikers across the entire Presidential Range.

The weather was the kind that made you remember why people died up here. Cold; the mercury around freezing. Wet; a thick sort of mist halfway between a drizzle and a rain. Windy; a chill below zero. At 4:30 PM, when I hadn't seen a single person in hours, the Gray Knob door opened and a man, Pat, sloshed inside the cabin covered in Gore-tex so soaked with rain it was plastered to his body. He mentioned a hiker in rough shape on Lowe's Path, accompanied by two others.

"Above tree line—I mean, just above tree line. The guy was really struggling... When I passed, the woman was going back to help. None of them speak good English." I did a mental inventory of the cabin. Plenty of food to heat water. Spare food. Loose bags of tea. Spare blankets. A woodstove. One of the largest medical supply caches in the Presidential Range. And two litters for carry-outs.

"What'll you do?" Pat asked.

"Probably make 'em come in here, give 'em some tea, get 'em warmed up," I said. He looked uncertain. "The guy was stumbling around. Almost couldn't walk. I mean, I don't know what point you call a rescue at, but..."

I decided to check the situation out first.

A few minutes up the trail I ran into a middle-aged man, Charles, with hiking poles and a relatively lightweight backpack. Around the corner, I saw where Pat had been wrong — the imperiled hiker was the woman, and middle-aged, not younger, as he had said — and how he had been right. The woman, Lucie, was sitting in the shrub with a look of fear dulled to near blankness by confusion. She wore only leggings, a light synthetic top, and a headband, all of it heavy with rain.

"I work at the hut! It's very close — we will go there to get warmed up!" I smiled at the woman the way I smiled at young children. Eric and I grabbed Lucie's arms and helped her up. She stumbled forward a few steps, then muttered, "I want to sit down," and plopped back into the alpine scrub. This was bad.

*continued on page 5*

Camps, October airlift and winter caretakers ..... pages 6,7  
Trails and Volunteer Work Trips 2022 ..... pages 8,9  
Treasurer's Report / RMC Employee Alumni ..... page 10

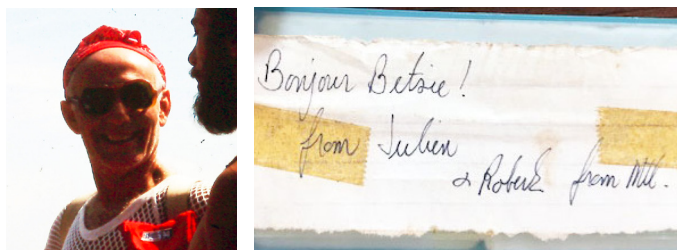

## Fifty Years of Women on the RMC Trail Crew

by Josie Bourne

While perusing the pages of *Peaks and Paths* this past summer, I noticed that 1972 had been the year of the first female member of the Randolph Mountain Club trail crew; that was fifty years ago! Betsy Segura (née Rising) was that trailblazing summer employee, and she is still a member of the club today. To commemorate this anniversary, I connected with her recently to learn about the season she spent on the trail crew when she was seventeen years old.

Betsy's family had a summer place in Randolph, so she grew up immersed in the trail culture there. She recalled hiking the Glen Boulder Trail at age three or four, carrying up Hawaiian Punch in cans. Her older brother worked on the trail crew, and many of her peers were involved with the club. In 1971 she volunteered on RMC trails, and then in 1972 officially became a crew member, forgoing a summer tour to England with the Greater Boston Youth Symphony Orchestra.

*continued on page 5*

Above, Betsy and Bill Rising (right) at old Crag Camp with caretakers Tad Pfeffer and Woody Canaday, c. 1971; 2nd row, one of Betsy's favorite overnight guests, "Julien from Montréal", and his note. Photos courtesy of Betsy.

*Also in this issue:*

The RMC's New Strategic Plan ..... page 3  
New RMC Directors ..... page 3  
2021 Summer Events and Annual Meeting photos ..... page 4

**Randolph Mountain Club 2022-2023**

Officers, Directors,  
committee chairs and honorary members

**President** John Phinney, Randolph NH  
**Vice President** Carl Herz, Seattle WA  
**Treasurer** Adam Berger, Seattle WA  
**Secretary** Joel Douglas, Andover MA  
**Clerk** Sally Micucci, Randolph NH

**Other Directors:** Tom Breunig, El Cerrito CA  
 Chris Cross, New York NY  
 Maryka Gillis, Providence RI  
 Chris Hawkins, Randolph NH  
 Ben Lieberson, Roslindale MA  
 Jenna Maddock, Boulder CO  
 Deva Steketee, Turner ME  
 Ginny Umiker, Randolph NH  
 Wendy Walsh, Randolph NH  
 Howie Wemyss, Randolph NH

**Camps** Pete Antos-Ketcham, Adam Ritchie  
**Trails** Ben Lieberson, Tim Mather  
**Events** Ginny Umiker, Redza Dempster  
**Merchandise** Michele Cormier  
**Planned Giving** Randy Meiklejohn  
**Membership** Michele Cormier  
**Trips** Mary Minifie  
**Work Trips** Wendy Walsh  
**Stearns Lodge** Howie Wemyss  
**Revenue Dev't.** John Phinney  
**Communications** John Phinney  
 - Newsletter Randy Meiklejohn  
 - Website Jenna Maddock  
 - Social Media Carl Herz, Jenny Baxter,  
 Maryka Gillis  
**Archivist** Al Hudson  
**Historian** Judy Hudson

**Honorary members** Bill & Barbara Arnold  
 Paul & Michele Cormier  
 Al & Judy Hudson  
 Edith Tucker

[www.randolphmountainclub.org](http://www.randolphmountainclub.org)  
 Facebook: [RandolphMountainClub](https://www.facebook.com/RandolphMountainClub)  
 Instagram: [@randolphmountainclub](https://www.instagram.com/randolphmountainclub)

*The Randolph Mountain Club is a diverse organization, committed to equal opportunity in employment and program delivery. The RMC prohibits discrimination on the basis of race, color, national origin, sex, religion, age, disability, sexual orientation, gender identity, gender expression, military status, veteran status, income level, political affiliation and familial status.*

*From the President ...*



2022 presented challenges that the RMC successfully navigated under the leadership of past president Randy Meiklejohn. The club owes him a debt of gratitude for his service and for his part in developing a Strategic Plan (*page 3*) which outlines the RMC's path forward! The process highlighted changes we face with membership demographics contemporaneous with increasing federal and state interactions, all the while continuing important traditions and a culture of community and comradery that has defined the club for over a century.

For community and comradery, the Events Committee has scheduled a "Fever Reliever" dance at the Town Hall for the winter, simultaneous with the launch of an on-line RMC sign auction. These events will appear on our forthcoming new website that Jenna Maddock, Tom Breunig, and Eric Scharnberg are bringing to fruition. The website will realize the strategic plan's vision of our comprehensive virtual presence.

Other fund-raising activities in 2023 will accompany the sign auction. Adam Berger's Treasurer's Report (*page 10*) shows the pandemic-related financial fallout hit the club hard. A newly formed revenue development Team will tackle the financial realities head-on, and explore new avenues to fund our operations and plan for capital expenditures.

After much agonizing the board has raised overnight guest fees for the camps, and increased the differential between member and non-member rates. These actions follow the plan for Increased and Sustained Revenue to combat increased operational costs. We will explore new membership tiers and sponsorships, to help make the club and its camps affordable for all.

For the Camps Committee, we are pleased to have Pete Antos-Ketcham and Adam Ritchie as new Co-Chairs. At the same time, Tim Mather has joined Ben Lieberson as Trails Co-Chair. Bob Drescher and Carl Herz are now retiring from Trails and Camps leadership, respectively, and it is hard to find words to describe the immense contributions Bob and Carl have made to the RMC and the positive impacts they have had on our employees, many of whom are now our engaged "alumni."

We are pleased Redza Dempster has joined Ginny Umiker as Events Co-Chair. He succeeds outgoing Co-Chair Franklin Stone Wenk, who for many years has helped strengthen the community culture of Randolph through the success of RMC events.

Finally, a special word of thanks to immediate past Treasurer Kathleen Kelley, who developed processes and procedures that ensure the RMC's stability in an ever-complex world of grant applications. Kathleen has better positioned us to meet financial challenges ahead.

The RMC is poised for a great 2023 and it will be a year of frequent dialogue between membership and their Board who together will implement the RMC's strategic plan!

John Phinney, President  
 email: [president@randolphmountainclub.org](mailto:president@randolphmountainclub.org)



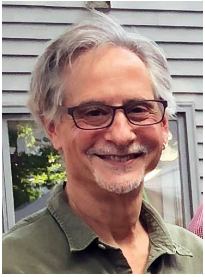

Adam Berger



Chris Cross



Sally Micucci

**New RMC Directors**

*for three-year terms; elected by members at the 2022 Annual Meeting*

**Adam Berger**, who was elected as the new Treasurer at the board meeting in August, was first brought to Randolph almost thirty years ago, by Harriet Phinney. The two married in 1995 and have consistently returned here in summers (look for them onstage in the Midlands charade) along with their children Elijah and Alana. The rest of the year they live in Seattle. Adam, originally a public interest environmental litigator for Earthjustice, works now as a plaintiff’s trial attorney.

**Chris Cross** is a lifelong Randolphian, and generations of his family have been in the town and in the RMC since the late nineteenth century. He became a hiker, skier, climber and hunter while growing up here year-round, and remains active outdoors, hiking the RMC’s trails in winter, riding his gravel bike up the Jefferson Notch Road, gardening with his wife Pauline and foraging for mushrooms in the woods. When they aren’t in Randolph, Chris and Pauline live in New York City where he is a partner in a law firm.

**Sally Micucci** became a year-round resident of Randolph in the 1990s, shortly after moving to the North Country from her native England, to begin a hospital job as a physical therapist. She has previously served on the RMC board, as did her late husband Mike Micucci, a longtime officer, Trails chair and outdoorsman. Sally originally connected with the club through work days on the RMC trails. After years of helping with handwritten thank-you’s, she is pleased that the RMC has gone digital in its member communications.

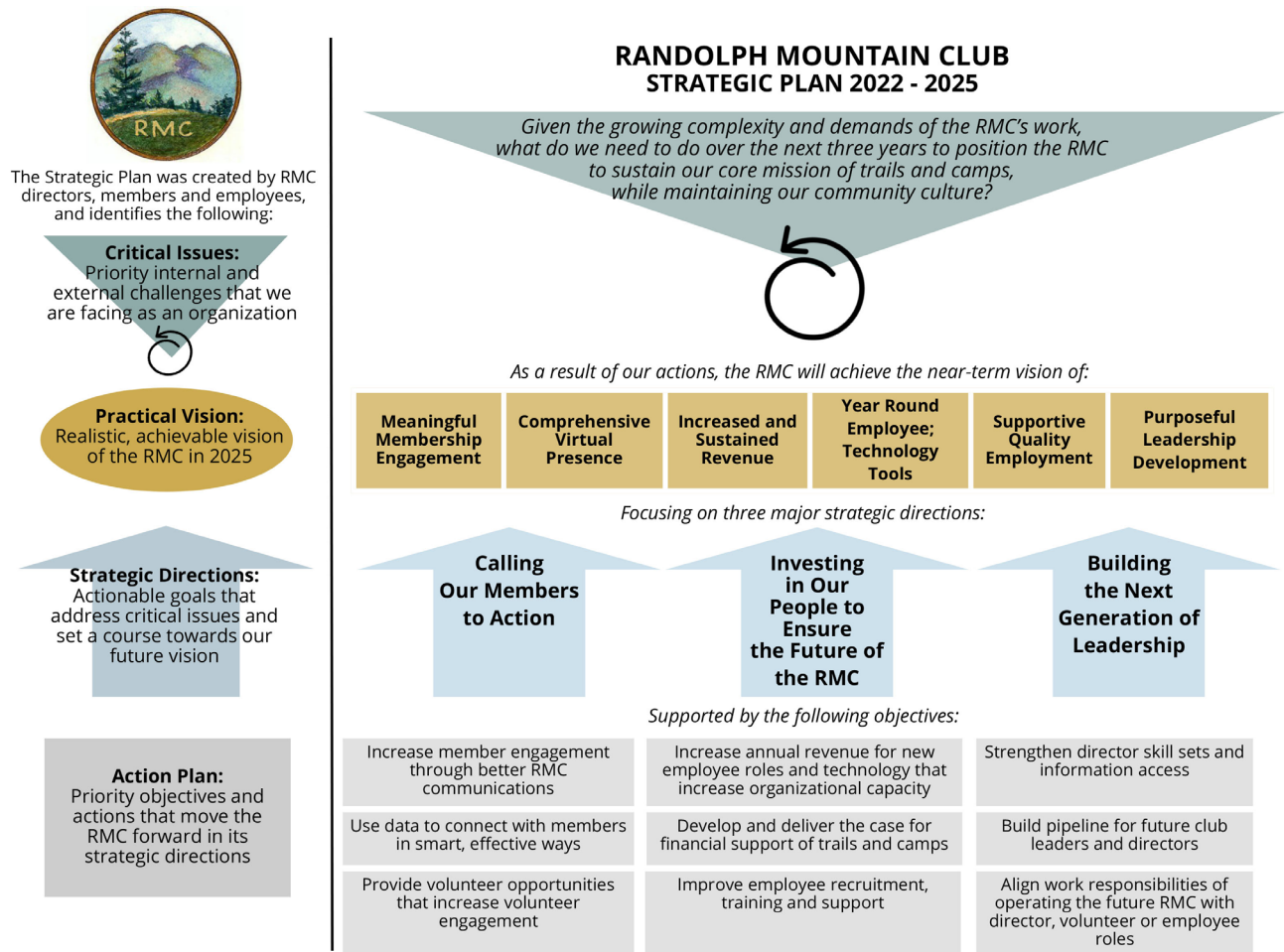

**The Strategic Plan:** Above is page 6 from the six-page Strategic Plan document created on August 1, 2022, and presented at the Annual Meeting on August 13. It is the RMC’s first Strategic Plan, and represents a return to the type of long-range planning work last done in the late 1990’s, which led to the construction of Stearns Lodge. This one-page summary is accompanied by a detailed action plan (for use by the RMC board), with ten to fourteen “significant actions” for each of the three Strategic Directions in the plan. The identification of these significant actions is intended to guide the work of the board of directors over the next three years.



**Events and Meetings in 2022**

*Community gatherings in July and August, including official RMC events and others featuring RMC employees or benefiting the club. Photos by Franklin Stone Wenk and others.*

From top left: Phinneys at the Libby's dinner; Thomas Strayhorn at the RMC benefit concert; Midlands charade at the Picnic; Limmer Boot wearers at the Annual Meeting; Gourmet Hike to Pine Mtn.; a "Porches" fundraiser to benefit the RMC and other community groups; Picnic audience in Mossy Glen; 4th of July Tea servers; trail crew making music at the Library; in-person again at the Annual Meeting; a table at the Libby's dinner.





*50 years of Women on the Trail Crew, cont'd. from page 1*

Betsy spoke fondly of her times on the crew, describing how they would clear and brush the trails using sickles, axes, and saws. The crew often paid particular attention to their favorite spots. She noted “the Perch Path didn’t really need it, but it got blitzed...and didn’t need to be brushed for ten years after.”

Much of what she described resonated with my experience as a contemporary member of the crew: the feeling of pride in a heavy pack, the unwavering loyalty to Limmers, the love of the mountains. Even the masochistic fun of wrecking one’s knees on the Spur Trail strikes a chord. While the work the crew does has changed, with construction of trail structures like stairs or water bars forming a larger part of the season, the same feelings are still common amongst crew members.

Betsy insists that she is only part of a long line of notable women in Randolph, including hikers, trailbuilders and leaders such as Anna Stearns, Mildred Horton, Lucia Cook and Marian Pychowska. She did not think about being the first woman on the trail crew at the time, because she grew up in Randolph, and climbing with other families was so normal. Still, the seasons on crew and at Crag were impactful: “Looking back, I see it affected my life, but if it wasn’t me, it would have been somebody else. Looking back, I am proud of it. It was just something I thought I could do, so [they should] hire me, and it never even occurred to me that they would discuss it.”

For my part, I still remember the first woman I met working in outdoor recreation, on a local day crew hosted by the Upper Valley Trails Alliance. It was after my freshman year of high school, and I met a National Parks employee who spent the week with us. Representation is critical: if you can see it, you can be it. I am grateful to Betsy for being the first, so that I and many others of diverse gender identities can continue to joyfully live, work, and play as part of the RMC community.

*Josie Bourne (she/her) was an RMC trail crew member in 2021 and crew leader in 2022. She enjoys hiking, skiing, and mountain biking, and hopes to make her way back up to the northern Presidentials in the near future!*



Left, Josie Bourne in 2021, bottom row left, in the trail crew’s human cairn at Thunderstorm Junction (Sam Marshall photo). Right, Betsy Rising Segura playing her horn outdoors, in Mexico where she now lives (courtesy photo).

*Hiker Rescue, cont'd. from page 1*

This was someone sitting down with the intent not to rise until the danger was past, but the only way to get out of danger was to keep moving.

Back at Gray Knob, it was a flurry of activity I’d gone over many times before in my mind. Calling, gathering supplies. Three years previously I’d had to call together a rescue team; the year before, I’d gone out on one myself. But this was the first time I’d been the first on the scene. And as I was calling the Crag caretaker Renée, she was, as I later learned, reading *Not Without Peril*. A book I told anyone who spent a good amount of time in the Whites to read, not as a scare tactic, but to appreciate the full life-saving and life-taking power of the place.

The phone kept cutting in and out. “Cold hiker, come to Gray Knob, then come up Lowe’s!” I said.

I directed Pat to light the fire, gathered layers from my own stash, and ran back up the mountain again. By the time Renée arrived, Lucie could no longer hold her own weight. Eric and I were trying to carry her but failing. I didn’t want to resort to the litter, a clumsy and time-consuming option, but there wasn’t a choice.

What would they have done, if Pat hadn’t found them? Would they have kept going down the mountain? Eric offered to help, but we needed fresher bodies. I was left with Lucie as she slowly lost her strength and collapsed into me like a doll.

“What’s your name?” No answer.

“Do you know where you are?”

I spoke to her very mechanically: This is where you are. You’re cold but we’re going to help you.

By pressing the beds of her nails I could see how long it took the blood to return, a sign of how hypothermia affects the extremities. The refill was faster than I would have expected, and she was even jerking out a few shudders, halting shivers, a sign of milder hypothermia.

Again and again she muttered, “je souffre.”

Renée arrived with a pack of hypothermia gear.

“Does she know what’s going on?” he asked.

“We can’t know,” said Renée. She had completed her WFR a month before and instructed us on how to make a thermal wrap. The radio crackled. Bill Arnold. “How long of a carryout are we looking at?”

I hesitated. We were less than a tenth of a mile from the cabin, but each step was treacherous. I knew an estimate of an hour was reasonable but Pat had never been on a rescue before, and I didn’t want to demoralize him before we’d started. “Um, forty minutes?” An hour of rain pouring into our shoes. Our hands slipped on the railing and our boots on the rocks so that every now and again someone would stumble.

Every few feet we had to set down the litter to readjust, calculate a route over a boulder, or simply give our hands a rest. Mine would give out after ten minutes of clenching. And all the while Lucie would moan every time we lowered or lifted her.

Pat looked at her. “You’re sure she didn’t have another injury?”

“Not sure,” I said. “Renée, did you check her for anything else?” She shook her head. No. The primary method of injury seemed to be hypothermia.”

*continued on page 11*



### Airlift to the RMC Camps

by Chris Hawkins and Wendy Walsh

Every September we plan an airlift to the camps, after the end of the summer season, but September 2022 proved to be extremely windy and rainy. This year’s airlift was rescheduled multiple times, ultimately to October 5th, and it was a successful operation, thanks to the many volunteers and RMC trail crew members who came out to help on that day. At 8:30 in the morning volunteers arrived at Kenisons’ field between Durand Road and US Route 2, to start loading Bio Bricks, mulch, propane and other supplies. Volunteers included RMC President John Phinney, Treasurer Adam Berger, Harriet Phinney, directors Chris Hawkins and Wendy Walsh (from Camps and Trails committees, respectively) and Randy Noring. Volunteers are also needed at the top end, to unload supplies at on the mountain at Gray Knob, Crag Camp, and the Perch, and this year they included Trails Co-Chair Tim Mather, Jeff Wilson, Field Supervisor Sam Marshall, and Josie Bourne, Reuben Morris and Matt Jaffe from the trail crew. Most important is Judy Kenison - her field is ideal and allows quick work. Thanks Judy!

What does it take to plan and execute an airlift? The RMC hires Mark Hitchcock of Maine Helicopters from Whitefield, Maine. Mark is a seasoned pilot and knows the White Mountains, having worked for the AMC construction crew, and he first learned to fly helicopters in Antarctica. It takes approximately 15 minutes for the Bell 206B helicopter to fly up to one of the unloading spots and fly back to the valley. A typical load is 800 pounds, depending on helicopter fuel levels and wind. This Fall there were twenty-two in-loads of supplies going up the mountain and eight down-loads of trash and trail construction rigging. Unlike past airlifts, mulch and construction materials were flown to directly to the Perch and the Log Cabin (rather than Gray Knob only). Sam and Josie did stellar work receiving construction materials and bark mulch, and hooking out loads. Airlift time totaled 4 hours and 20 minutes, at the cost of \$8,062.00. Yes, that’s a lot of money....

In the long history of RMC operations on the mountain, helicopters are a relatively recent addition, being first employed to fly construction materials to The Perch in 1989. The Board agreed it would save hours and hours of backpacking, and be well worth the price! Next came airlifts for construction of the new Gray Knob in 1989 and the new Crag Camp in 1993. Fall airlifts became an annual routine more recently, in response to the Forest Service ban on cutting firewood to heat Gray Knob (where we now use Bio Bricks), and the need for bark mulch for the composting toilets at the camps.



From top: Mark Hitchcock, Chris Hawkins; Wendy Walsh and volunteers at Kenisons’ (C. Hawkins photos). Above, the airlift in action, seen from the Quay (left, Tim Mather) and from Gray Knob (right, Adam Ritchie).

At right, the new benches designed and built by Adam Ritchie: 2-D and 3-D diagrams, and the benches in place on the Crag deck in October. Drawings and photo by Adam.

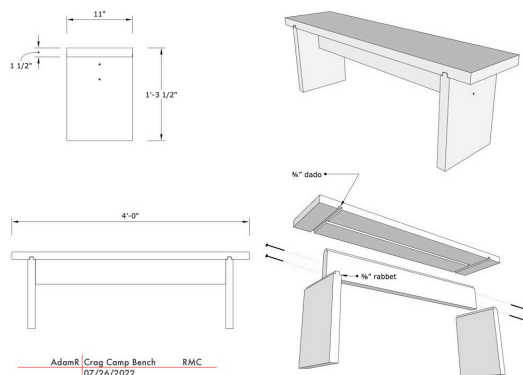



## Camps Report

by Carl Herz, outgoing Camps Chair

Summer at the camps this year was the beginning of the return to normal operations. Occupancy limits were lifted, and we welcomed guests at historic shelter capacity. We benefitted enormously from the enthusiasm and professionalism of our caretakers, Andi Smith and Renée Koma. The two handled a multi-hiker emergency (*see page 1*) on a particularly cold June weekend without any support on the ground, and it's my firm belief that they saved a life. When fall came, the new employees we expected were unable to start their work as caretakers, and we had to scramble to staff the camps for the season. Fortunately, some trail crew members were willing to take a turn at the camps, and others filled in as short-term caretakers. It is our hope that some of them will return for future seasons!

In the fall airlift (*see page 6*) three and a half tons of wood fuel and several tanks of propane were flown up, in addition to a smattering of new board games, poker chips, decks of cards and new cookware for the caretaker stove. Adam Ritchie designed and built two beautiful benches to replace the old rotten ones that have long stood on the porch of Crag Camp - these too were flown up during the airlift. RMC carpenter John Tremblay finished all repairs on the compost drying racks this year. The temperatures were too low for the other project we had planned on, which was sealing the Perch shelter with modern color blended caulking, so this will be done next year.

As operational costs and supply prices have increased, we have found a rate increase at the camps unavoidable. Effective November 1, the new member rates at the camps are as follows: Crag Camp, Gray Knob: \$30. Perch, Log Cabin: \$15. The non-member rate at Crag Camp and Gray Knob is now \$50, Perch and Log Cabin \$20. To remain competitive in recruiting qualified caretakers, we have raised their pay as well.

Having chaired Camps since 2019, I am now stepping aside to fulfill the duties of RMC Vice-President. I will remain on the camps committee as we continue to focus on enriching the experience of our employees and guests.

## Camp Caretakers, Winter 2022-23

in their own words

**Austin Kemp** (*left photo, by Jim*): I'm from Waterbury VT, and I am a carpenter, outdoorsman, book, board game and tech nerd; I like to ski, mountain bike, hike, hunt, and camp. This is my first season as a caretaker in the Whites, and I'm excited about reducing my carbon footprint by living low-impact on the mountain, and hoping to gain an intimate knowledge of the surrounding peaks, ridges, and gullies.

**Jim Baum** (*right photo, by Austin*): Back again from Mount Airy NC, reporting for my 4th winter as Gray Knob Caretaker, 2019-2022! Some of my other adventures have included : Appalachian Trail Conservancy Ridgerunner Tye River 2019-20 and Mount Rogers NRA 2021-2022. I'm very excited to be back up at the camps and greeting hikers for another winter.



Above, Gray Knob glowing on a starry night (Andi Smith photo); camps Co-Chair Adam Ritchie awaiting the airlift (courtesy photo).

At left and below, the compost drying rack at the Log Cabin, before and after this summer's repair and improvement work (John Tremblay photos).





## Trails Report

by Bob Drescher and Ben Lieberson

Each year the RMC Field Supervisor chronicles the summer and fall seasons in a report to the Trails Chair and the board, explaining the projects, providing work counts, and conveying impressions of the crew. Here’s an excerpt from Sam Marshall’s 2022 report, supporting the Trails Committee’s take that this indeed was a very successful season:

*“Much like last year, the trail crew this summer was energetic, hard-working and eager to learn. This enabled us to complete excellent work on the Diagonal and the Gulfside, and contributed to everyone’s enjoying the summer. The high number of returning crew members, the similarity of this season’s work to last summer’s, and having a full crew for the first time since the pandemic enabled us to hit the ground running with both projects.”*

The experience and leadership provided by Sam, and by crew leaders Joey Schilke and Josie Bourne, played a vital role in making this happen. Sam and Justin Taylor also invested significant time during the past year working with the ArcGIS collector app (software that uses interactive maps and analyzes data to share and collaborate). By adapting this program to the RMC’s trail system, we’ll be able to share trail assessments more readily with the Forest Service and with other partners, and to create and manage a trail inventory for planning trail projects and grant writing.

The Club’s continued investment in improving the work environment played a big part in securing returning crew members. We have increased the crew’s hourly wages and provided additional funding for food (which is invested in CSA). Our training programs, which included in-house sessions with former field supervisors Ben Lieberson and Justin Taylor, have also been energized with USFS certified chainsaw and axe classes for the entire crew and a First Aid/CPR course with the Gorham Fire Dept./EMS.

Projects this year included replacing forty bog bridges and a four-step rock staircase with rock waterbar and stepstones on the Diagonal, a popular connecting trail within Randolph, largely funded by a NH Recreational Trails Program grant. In our second and final season on the Gulfside Trail (part of the Appalachian Trail) we completed screewall construction, rock steps and other trail hardening to protect alpine vegetation near Peabody Spring, on the south side of Mt. Sam Adams. Between the spring and the northern junction of the Gulfside with the Israel Ridge Path, the crew built 170 feet of screewall and twelve cairns. Funding for this important work came from the Appalachian Trail Conservancy, where the RMC has been an Affiliated Maintaining Club since 2011.

The fall crew spent time finishing up work on the Diagonal, and also replaced bog bridge stringers on the Howker Ridge Trail and the Randolph Path, repaired a wooden staircase on Starr King, installed a wood waterbar on the lower Sargent Path and assisted with the October airlift to the camps.



Above, Joey Schilke sawing lumber for the Diagonal; Reuben Morris and Julia Rudlaff replacing end-of-life bog bridges nearby; a new stone stair further down the trail, and the staircase on Starr King. Below left, field assessment of the Gulfside on a dry day in 2019, and at right in 2022 with its new screewall and water running in the trail (from Peabody Spring) as it usually does. The bottom photos show the crew moving a large “step rock” into place, to encourage hikers to stay on the trail and out of the alpine vegetation. Photos by Sam Marshall, Josie Bourne.







This year forty-seven volunteers worked on RMC trails, some working more than one day, for a total of 556 hours. This is a notable increase from last year in both the number of volunteers and total hours worked (in 2021, twenty-nine volunteers worked 250 hours). Thank you to all the first-time volunteers as well as the many regulars who make a commitment every year to work on the trails. Two especially dedicated volunteers, Amy Patenaude and Bria Clark, came out six days to work on several trails including the Ice Gulch Path, the Cook Path, the Four Soldiers Path, the Crescent Ridge Trail, The Link, and several paths on Randolph Hill. Brushing The Link was a major accomplishment, as Amy describes: “we felt more often that we were trail building rather than brushing and trimming an existing path.”

This year the RMC was granted funds by the New Hampshire Recreational Trails Program for our trail crew to carry out erosion control and establish new bog bridges on the Diagonal. If you have not checked out the new bog bridges, it is worth a trip. This grant required a 20% match by the RMC, some of which could be covered by volunteer work on site. On July 9th, seven RMC Trail Crew alumni joined Trails co-chairs Bob Drescher and Ben Lieberson, carrying heavy bog bridge timbers to sites along the Diagonal for the summer trail crew to install. On July 30th, an amazing sixteen volunteers came out to help, possibly a single-day new record! In total, volunteers worked 119 hours on the Diagonal, which accounted for \$3,172.00 towards our match for the grant.

Volunteers also worked on the Pasture Path, the Cliffway, the Owl’s Head Trail, the Short Circuit, the lower King Ravine Trail, the Randolph Path, the Inlook Trail, and the Great Gully Trail.

Thank you all who came out to help with essential work on our trails, alongside friends, neighbors and new RMC members. Some volunteers came out for more than one trip, as indicated by a number after their name; \* indicates Trail Crew alumni.

Above, left to right: Christoph Geiss and Brandon Rich painting blazes on the lower King Ravine Trail; Lucas Geiss and Oliver Geiss taking a break after brushing on the KRT; Stuart Johnson and Tim Mather brushing at the top end of the Diagonal, near the Pasture Path; Patty Watson and other volunteers opening up the view to Vermont on the Inlook Trail ledges. Below, before and after brushing on The Link, Caps-to-Castles section. Photos by Wendy Walsh, Randy Meiklejohn and Amy Patenaude.



## Volunteer Work Trips on RMC Trails, 2022

by Wendy Walsh

### Roster of 2022 Trail Volunteers:

Steve Barrow  
 Tommy Barrow  
 Jenny Baxter\*  
 Brian Behr\*  
 Dwight Bradley  
 Ben Brownell  
 Chris Campbell\*  
 Amy Carey  
 Megan Carey\* (2)  
 Bria Clark (6)  
 Ed Clark  
 Ray Cooper (3)  
 Bob Drescher (8)  
 Rachel Flaksman  
 Christoph Geiss (4)  
 Oliver Geiss (3)  
 Lucas Geiss (3)  
 Lynn Hettinger  
 Stuart Johnson  
 Beth Krusi  
 Ben Lieberson\* (2)  
 Tai Man\* (2)  
 Tim Mather (9)  
 Ted May  
 Laura May  
 Randy Meiklejohn (2)  
 Anders Morley  
 Randy Noring\*  
 Danielle Normand (2)  
 Joan Ostergren  
 Amy Patenaude (6)  
 Tad Pfeffer\*  
 Ben Phinney  
 John Phinney (2)  
 Brandon Rich  
 Doreen Roy (2)  
 Eric Sandin  
 Deva Steketee\*  
 Jim St. Cyr  
 Dave Tomlinson  
 Alison Tomlinson  
 Wendy Walsh (4)  
 Joanne Wang  
 Patty Watson  
 Howie Wemyss (2)  
 Andy Wiley  
 Jeff Wilson (6)



**Treasurer's Report***by Adam Berger*

	Admin.	Dev't.	Camps	Stearns	Trails	Trails Grants	Total	Budget
<b>Revenue</b>								
YTD 10/22/2022:	\$49,982	24,375	23,661	0	148	1,220	102,667	144,675
<b>Expense</b>								
YTD 10/22/2022:	\$31,653	959	32,835	10,390	49,475	39,638	168,231	151,391
<b>Net:</b>	\$18,329	23,416	(9,174)	(10,390)	(49,327)	(38,418)	(65,564)	(6,716)

At the end of the third quarter, RMC was running nearly a \$66,000.00 operating loss. This deficit is due in part to the fact that approximately \$42,000.00 in grant-funded trails expenses have not yet been invoiced to the granting agencies, because the work continued into October 2022. However, that still leaves a very real deficit of over \$20,000.00 that is driven primarily by two factors.

First, Camps fees remain significantly depressed, falling over \$12,000.00 behind budgeted levels. Second, payroll expenses for Trails were approximately \$10,000.00 over budget due to a combination of higher than anticipated wage rates for some crew members, project management expenditures early in the year, a larger crew (particularly in the fall), and a slightly longer work season. Payroll for Camps is on-budget currently, but due to increased wage rates for fall and winter caretakers, will exceed budget for the remainder of the year. Similarly, food expenses for the trail crew have exceeded the Supplies/Other Expenses budget lines for Trails. These increased expenses will likely persist into FY23 due to inflationary pressures and changed labor market conditions.

Other significant expense overages include accounting fees (due to the greater outsourcing of functions previously performed by the treasurer), and utilities, maintenance, and supplies at Stearns (due to increased electrical and gas prices, acquisition of a new oven and two large tents, and acquisition of a laptop computer and installation of internet at the lodge). The recent airlift to the Camps was also \$1,000.00 over budget, although it does not show up in the Q3 reports.

The overall financial picture indicates a need to increase revenue on several fronts to ensure the continued health of the RMC. Upward wage and fringe pressures and ongoing inflation (especially with regard to utility costs, food, and contract services) will increase the financial demands on the organization in FY23 and future years. These can be offset to some degree by increasing camp fees and revenues, but exploration of other revenue sources is warranted, particularly if we want to achieve the strategic planning goals of obtaining full-time paid staff to oversee critical organization functions like trails maintenance, camp operations, and administrative functions.

**RMC Alumni Doings***by Jenny Baxter*

This summer saw the return of in-person club gatherings and renewal of favorite traditions, and many alumni jumped at the chance to participate. From logging 50 hours carrying bog bridging on the Diagonal to cooking up a low-country boil at the trail crew's end of season party, alumni showed up and didn't hesitate to join in.

We are also continuing our web series "*Tales from the Trails*", and on December 18 at 6:00 PM (EST), RMC's own Jordan Cargill (summer trail crew member and caretaker, 2012-14) will lead a discussion exploring the evolution of climbing in the White Mountains. "From cutting edge technical rock and ice climbers to National Geographic Explorers and Himalayan pioneers, the White Mountains have long been a crucible for the techniques and individuals at the forefront of vertical exploration." To join the discussion on what makes this modest range in the heart of New England such a durable monument in the climbing and mountaineering universe, and to get other information on upcoming alumni gatherings, send an email request to [randolphmountainclubalumni@gmail.com](mailto:randolphmountainclubalumni@gmail.com) or follow RMC's social media.

Tales episodes are available at our YouTube Channel:  
<https://www.youtube.com/channel/UC6bCk6tWp0a3LZcgfHkeANQ>.

Jordan Cargill; at upper left, leading on Angel Cakes at Frankenstein Cliff, in Crawford Notch. Courtesy photos.



We hope you'll like our attractive new colors for t-shirts, short sleeve and long, below; just a sample of what you can find at our online store. Find other apparel, maps and publications, pay dues, make a donation and so much more at: [www.randolphmountainclub.org](http://www.randolphmountainclub.org).

### RMC Merchandise

by Michele Cormier



**Robin Barr**, Barnegat NJ  
**Sean Brown**, Methuen MA  
**Coley Bryan**, Gloucester MA  
**Robert Bryant**, Cambridge MA  
**Susan Faunce**, Madison NH  
**Juan Fernandez**, Sharon MA  
**Rachel Flaksman**, Bridgton ME  
**Zbigniew Grabowski**, Canton CT  
**Todd Green**, Avon CT  
**Tim Gudas**, Concord NH  
**Christine Hedden**, Watertown MA  
**Andrea Huntoon**, Lincoln NH  
**Andrew Kelsen**, Naperville IL

### Welcome new RMC members!

by Joel Douglas, RMC Secretary  
 Joined May - October 2022

**Lydia Kennedy**, Vero Beach FL  
**Neils Knudsen**, Falmouth ME  
**Christopher Kujawa**, Rochester NH  
**Adam Lane-Olsen**, Intervale NH  
**Eric Littlefield**, Dover NH  
**Andrew Lombardi**, Portland ME  
**Shawn Maguire**, Ayer MA  
**Philip Major**, Syracuse NY  
**Terry Marshall**, Albany NH  
**Joshua Moran**, North Adams MA

**Matthew Myers**, Calais VT  
**Yvonne and Mike Perlmutter**,  
 Twin Mt, NH  
**Stephen Powell**, Enfield NH  
**Molly Regnier**, Jefferson NH  
**Brandon Rich**, Lebanon NH  
**Amber Riddle**, Tewksbury MA  
**Richard Rothman**, Swarthmore PA  
**Adam Schweisberg**, Merrimac MA  
**Alexandria Snider**, Cambridge NY  
**Aoife Troxel**, Somerville MA  
**Anthony Wilson**, Stoneham MA  
**Lucy Wyman**, Lancaster NH

### Hiker Rescue, cont'd. from page 5

Did I think of giving up at any point? Certainly I wished I was doing anything else, but I never for a minute wished someone else was doing this in my place. Patrick said out loud, "I'm not sure how much longer I can do this, guys," but he kept going. It was an impossible mission but just one more step was reasonable, so we took it. We were the only ones who could do the best anyone could do at the moment. We had to get her to Gray Knob. So we did it.

By 7:15 we were below tree line with a straight shot to Gray Knob. Even Lucie appeared to realize a change had occurred. For the first time in almost an hour she spoke, "I'm thirsty." "We'll be okay, madame!" Renée said in a crisp French accent. We hauled Lucie through the doors of Gray Knob. 77 degrees inside, 34 outside. We lifted the sides of the thermal wrap and shuffled over to a pile of mattresses and blankets, then stripped her out of her wet clothes and piled blankets atop her. Charles took our wet gear and spread it out. Renée started taking Lucie's vitals and I started calling people.

"Well, it's good to hear you made it, and it sounds like she's doing okay, and she didn't go into cardiac arrest on the way down. So that's good." Something I hadn't known was a possibility until after we were safe inside the doors of Gray Knob. Knowing wouldn't have helped.

From there, it was a waiting game. Waiting for the fire to cast warmth into our bodies. Waiting as Lucie gradually woke from her stupor, for an hour or so unable to say what had happened, but by 10:00 PM, able to sit up. I prepared instant mashed potatoes and Renée fed her hot sugar water.

"Do you want some potatoes? They will help warm you up!"  
 "Non."

A few moments later, she took the spoon.

Just after Renée left for Crag Camp, Lucie sat upright and exclaimed, "Oh! I'm thirsty!" And began to drink the sugar water of her own accord. And every few minutes, an episode of shivering would wrack Lucie's body, something we knew would happen, but also something Renée told me to eradicate before I let Lucie sleep. We all settled into our beds on the floor. I listened to their steady, even breathes, but found I couldn't sleep. My heart was calm. I wasn't panicked – hadn't felt that at any time during the rescue – but as I lay there I only floated on a sea of sleep, rather than sinking into its depths.

When Lucie awoke at 3am, I watched her walk like she was actually on flat ground. And by the next morning, she and Charles were ready to go.

I escorted them down Lowe's, past the Log Cabin. Both were a little unsteady, but no more than the average middle-aged adult who hadn't spent much time in the northern Presidentials. Once Lowe's Path flattened out, I said my goodbyes.

"Drink water," I told them. "Eat lots of food. And take rests!" Lucie smiled at me, her eyes no longer glassy but sparkling with awareness. She and Charles walked off into the trees.

I couldn't consider the rescue over until I knew they made it out. At 3:30 I called Sam and asked him to go to Lowe's and see if any "worried Québécois" were hanging around at the trailhead. "There's no one here," he said.

The new day was cold, gray, and cloudy, perfect for a nap.



## RMC Sign Auction Coming Soon

by Carl Herz and John Phinney

The Randolph Mountain Club has decommissioned a set of signs over the last few years, and we are pleased to announce that the next trail sign auction will be opening in early 2023! Watch RMC social media for updates, and you'll be able to view all of the signs at our website.

Trail signs are an iconic part of the hiking experience. It can be easy to take them for granted, especially on trails with which we are familiar. However, for those who have gotten turned around, or who find themselves rapidly descending from the alpine zone in bad weather, these simple signs can bring about an overwhelming sense of relief. Have you ever taken a break at an intersection and wondered how the posted signs got there, or how many hikers they have guided over the years?.

The RMC sign auction is a great opportunity to support the efforts of the club and our trails and camps. Beyond that, it is your chance to take home a piece of history. For the hiking or outdoor enthusiast, there is no finer gift.

At right, a few of the actual one-of-a-kind retired trail signs that will appear in the upcoming auction.

Photos by Carl Herz.

